

# ngpanel

ELECTRONIC CONTROL PANEL



BUILT-IN  
CONNECTIVITY



# NGPANEL

## ELECTRONIC CONTROL PANEL



### TECHNICAL DATA

**Single-phase power:** 1 x 230 VAC 50/60 Hz

**Three-phase power:** 3 x 400 VAC - 3 x 575 VAC 50/60 Hz

**Maximum operating current:**

1 x 29 A (1 x 230 VAC - 1 x 110 VAC)

1 x 12 A (3 x 400 VAC - 3 x 230 VAC)

2 x 12 A (1 x 230 VAC - 1 x 110 VAC)

2 x 12 A (3 x 400 VAC - 3 x 230 VAC)

2 x 20 A (1 x 230 VAC - 1 x 110 VAC)

1 x 8 A (3 x 575 VAC)

2 x 8 A (3 x 575 VAC)

**IP protection:** IP55 and NEMA 3R

**Room temperature:** -10°C +50°C

**Starting capacitor:** supplied as an additional kit

**Maximum altitude:** 1000 m. above sea level

**Certification:** CE, UL/CSA

Control panel for the control and protection of single-phase or three-phase pumps in residential, commercial and livestock environments, used for removing sewage and drainage water or filling (transferring) water into tanks.

The control panel protects the pumps and allows them to operate in automatic mode when connected to floats, level probes, or depth probes.

The graphic display allows for easy use thanks to the multilingual configuration wizard. It is possible to select the operating mode (filling or emptying) and the types of controls (floats, level probes or depth probes), or scroll through the alarm history.

The control panel features a self-extinguishing thermoplastic enclosure with IP55 and NEMA 3R protection class.

Various accessories may be combined with the control panel, such as controls (floats, level probes, depth probe) and capacitors for single-phase pumps, to be installed inside the panel itself.

Inside the control panel are: connection terminals for single-phase or three-phase power supply (L1, L2, L3); connection through single-phase or three-phase pump meters (U-V-W); connection terminals for thermal protection; three flashing light or siren alarm signalling output contacts.

NgPanel features Bluetooth and Wi-Fi connectivity, and can be managed using the DConnect app.

When there is no Wi-Fi connection, it is possible to use the DAB Wi-Fi Modem Kit, connecting it directly to the dedicated USB port inside the control panel.

The alarms displayed include: pump overheating or overloading, water leaks into the oil chamber, breakdowns or malfunctioning, excessive number of restarts. There is the possibility of calculating the amount of water pumped out of the collection tank.

# NGPANEL

## ELECTRONIC CONTROL PANEL

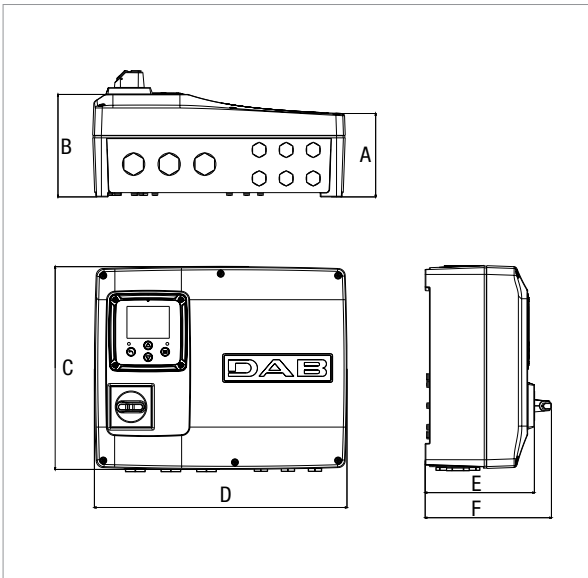

MODEL	A	B	C	D	E	F	PACKING DIMENSIONS			WEIGHT Kg
							L/A	L/B	H	
NGPANEL 1 PUMP 29 A	120	145	285	320	155	180	435	243	313	3,7
NGPANEL 2 PUMPS 20 A	120	145	285	320	155	180	435	243	313	3,7
NGPANEL 2 PUMPS 12 A	120	145	285	320	155	180	435	243	313	3,7

MODEL	VOLTAGE 50/60 Hz	STARTING	PUMP MAX CURRENT A	PUMP MAX POWER (P2) kW
NGPANEL 1 PUMP 29 A	1 x 230 VAC - 1 x 110 VAC	DIRECT	29	4,5
	3 x 400 VAC - 3 x 230 VAC		12	5,5
	3 x 575 VAC		8	5,5
NGPANEL 2 PUMPS 20 A	1 x 230 VAC - 1 x 110 VAC	DIRECT	20	2,5
	3 x 400 VAC - 3 x 230 VAC		12	5,5
	3 x 575 VAC		8	5,5
NGPANEL 2 PUMPS 12 A	1 x 230 VAC - 1 x 110 VAC	DIRECT	12	1,5
	3 x 400 VAC - 3 x 230 VAC		12	5,5
	3 x 575 VAC		8	5,5

# DCONNECT DIGITAL SERVICES

## REMOTE CONTROL FOR ELECTRONIC RESIDENTIAL AND COMMERCIAL SYSTEMS

The D.Connect service offers simple and intuitive remote control of your installation, without the need of a server or specialist personnel.

**With D.Connect, you can remotely manage your installations as if you were right in front of them.**

Thanks to the system operation charts, you will also be able to optimise operation. You will also receive prompt notifications of any system faults.

### THE SERVICE ALLOWS TO:

#### EASILY MONITOR YOUR SYSTEMS

The installations with green status are OK, while the orange ones need attention, and the red ones are experiencing problems.

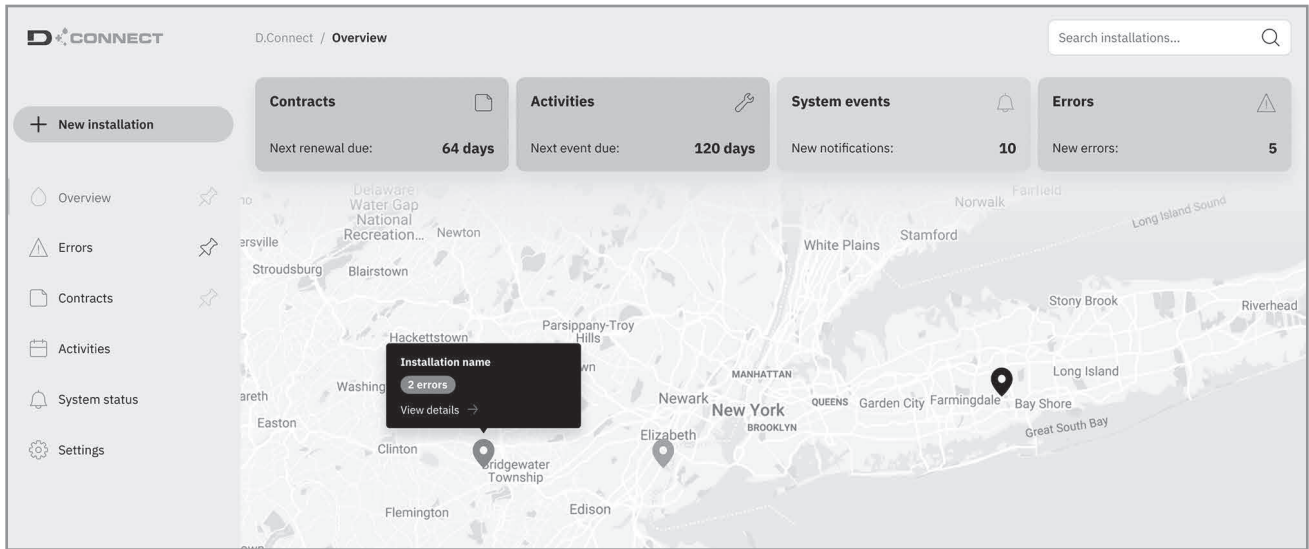

### TAKE ANY NECESSARY ACTIONS AS IF YOU WERE RIGHT IN THE PUMP ROOM

Using the internet site or the APPs, you will be able to easily and quickly control your systems.

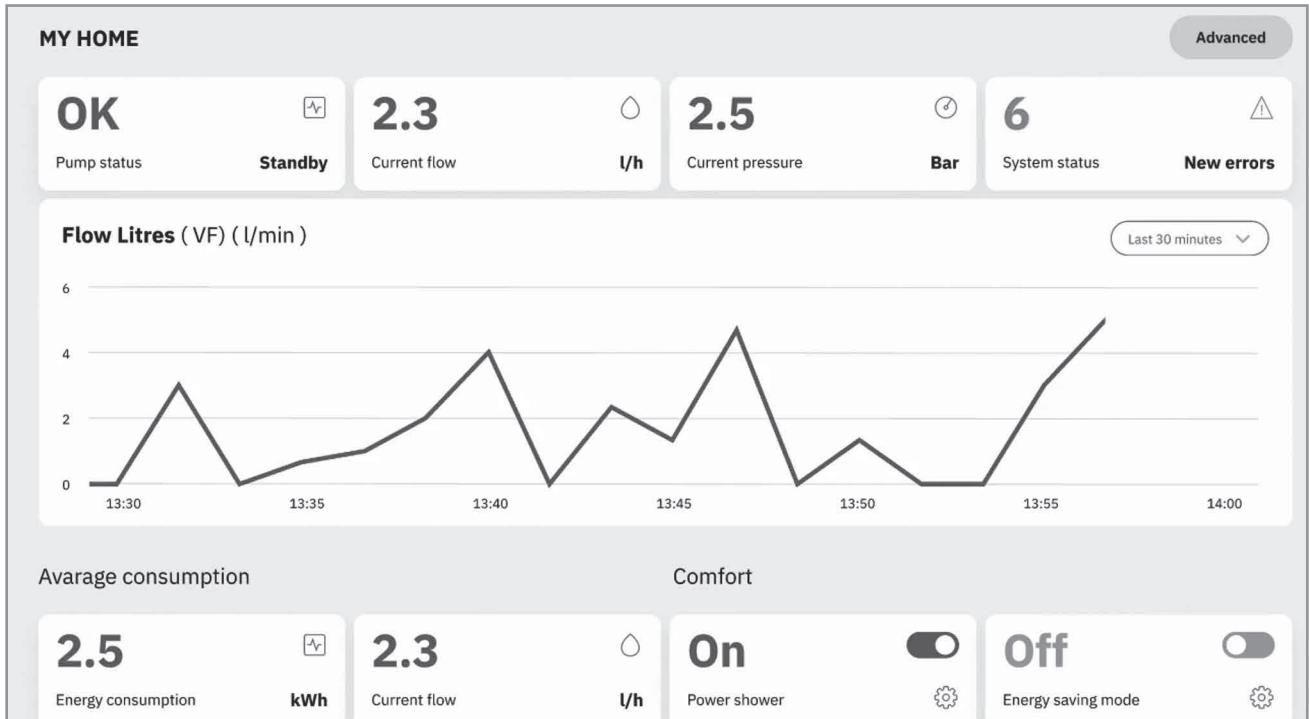

### REMOTE ALARMS

In case of alarm, the D.Connect service will promptly send you a notification, so that you can check what is happening and organise a visit to the system before the issue becomes an emergency for your customer.

# DCONNECT DIGITAL SERVICES

## REMOTE CONTROL FOR ELECTRONIC RESIDENTIAL AND COMMERCIAL SYSTEMS

In order to use the D.Connect service, registration and connected products are required.  
Connect to the website: <https://dconnect.dabpumps.com> using Internet Browsers such as Microsoft Edge or Google Chrome.  
The Android and iOS D.Connect APPs can be downloaded from the relevant Stores:

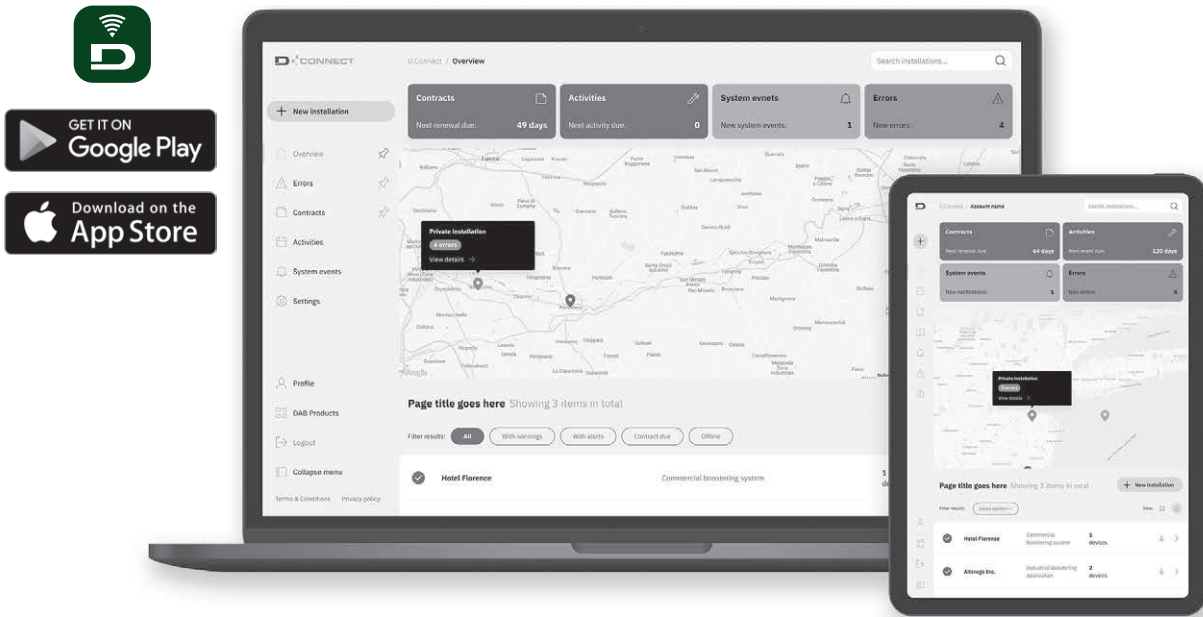

### WHAT PRODUCTS CAN YOU MANAGE USING THE D.CONNECT SERVICE?

NgDrive, NgPanel, MCE/P, MCE/C, ADAC, Active driver Plus, Ebox, Evoplus, Esybox, Esybox mini, Esybox Diver, Dtron 3, Esybox Max.

For more information visit: [www.internetofpumps.com](http://www.internetofpumps.com)



Simple and intuitive digital service for remote monitoring of DAB products: it allows you to find all the information you need, supervise the operation of the systems, or change the setting parameters.

### APP DAB LIVE! Available for Esybox mini<sup>3</sup>

It makes easier for end users to supervise domestic systems in order to optimize consumption and maximize comfort, also thanks to Power Shower and Sleep Mode functions.

## DCONNECT DIGITAL SERVICES

### DATA RETENTION 1 MONTH MONITORING AND CONTROL

**BASIC PACKAGE**

**1 YEAR SERVICE**

2 trial months included Possibility to upgrade to a higher package at any time.

**DATA PACKAGE**

**12 MONTHS SIM DATA TRAFFIC RENEWAL SERVICE**

### DATA RETENTION 12 MONTH MONITORING AND CONTROL

**PLUS 12 PACKAGE**

**1 YEAR SERVICE**

**PLUS 36 PACKAGE**

**3 YEARS SERVICE**

**KIT MODEM WiFi + WALL CHARGER + SIM**

**12 MONTHS OF TRAFFIC INCLUDED**

# USER INTERFACE AND PROTOCOLS

NGPANEL

## DAB SMART SYSTEM

Used in conjunction with **DAB Virtual Cockpit** and **DConnect**, it becomes a very smart system, with an intuitive and effective user experience.

Setting up the system is extremely quick thanks to the wizard: it takes 5 steps and 5 minutes to completely set up the plants.



## USER INTERFACE

Employing a consistent vertical scroll logic, the homepage also provides quick access to menus for the individual sections. On a single clear, user-friendly screen, **DAB Virtual Cockpit** summarizes all the key information to be monitored in order for the system controlled with **NgPanel** to work at its best.

The buttons are cross-arranged for easy interaction and the menu navigation symbols are intuitive.

**SYSTEM OPERATION STATUS**

**SINGLE PUMP STATUS**

**CONNECTIONS**

**TANK STATUS**

**CONNECTION TO THE DCONNECT APP**

	Press to browse the menu. Press to increment the selected parameter. Press and hold to increase the increment speed.
	Press to browse the menu. Press to decrement the selected parameter. Press and hold to increase the decrement speed.
	Press to confirm and go to the next screen. Press to access the selected menu page.
	Press to cancel and return to the previous screen. Press to leave the current menu page.



## PROTOCOLLI DI RETE

	<b>Bluetooth:</b> standard di trasmissione dati wireless, a corto raggio (punto a punto). È possibile collegare dispositivi come telefoni cellulari, personal computer, tablet. Collegamento tramite smartphone, direttamente a NgPanel in caso di configurazione da telefono tramite app DConnect.
	<b>WI-FI:</b> short-range wireless data transmission standard (point-to-point). You can connect devices such as mobile phones, personal computers, tablets. Connection via smartphone, directly to NgPanel in case of configuration from smartphone via DConnect app.

# ACCESSORIES

NGPANEL

	DESCRIPTION	
	<b>FLOAT KEY</b>	5 METERS
		10 METERS
		15 METERS
		20 METERS
	<b>BULB-FLOAT</b>	10 METERS
		20 METERS
	<b>DEPTH SENSOR 0-5 MT- 20 MT. CABLE FOR DRAINAGE WATER</b>	
	<b>LEVEL PROBE FOR DRAINAGE WATER</b>	

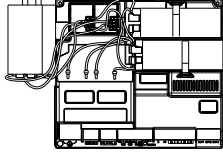
	DESCRIPTION
	<b>FLASHING 230V 5W 50/60 HZ</b> Equipped with a 5W incandescent bulb (The alarm outputs are free contacts and must be powered.)
	<b>ACOUSTIC ALARM -- 230 V - 50 HZ</b> (The alarm outputs are free contacts and must be powered.)
	<b>GRINDER CAPACITORS KIT</b> ONLY for 60Hz single-phase Grinder FX pumps.



It is also possible to find further information and technical details from DNA by connecting to the address: [dna.dabpumps.com](http://dna.dabpumps.com)

# DNA<sup>®</sup>

PUMPS SELECTOR



## On-line product selection



**DAB PUMPS LTD.**

Unit 6 Gilbert Court  
Newcomen Way, Severalls Park  
CO4 9WN  
Colchester  
ordersuk@dwtgroup.com  
Tel. +44 0333 777 5010



**DAB PUMPS IBERICA S.L.**

Calle Verano 18-20-22  
28850 - Torrejón de Ardoz - Madrid  
Spain  
Info.spain@dwtgroup.com  
Tel. +34 91 6569545



**DAB PUMPS (QINGDAO) CO. LTD.**

No.10 Xindong Road  
Jiulong Town,  
Jiaozhou City  
266319 Qingdao (Shandong) - China  
sales.cn@dwtgroup.com  
Tel. +86 400 186 8280  
Fax +86 53286812210



**DAB PUMPS BV**

\*Hofveld 6 C1  
1702 Groot Bijgaarden - Belgium  
info.belgium@dwtgroup.com  
Tel. +32 2 4668353



**DAB PUMPS HUNGARY KFT.**

H-8800  
Nagykanizsa, Buda Ernő u.5  
Hungary  
Tel. +36 93501700



**DAB PUMPS DE MÉXICO, S.A. DE C.V.**

Av Amsterdam 101 Local 4  
Col. Hipódromo Condesa,  
Del. Cuauhtémoc CP 06170  
Ciudad de México  
Tel. +52 55 6719 0493



**DAB PUMPS POLAND Sp. z o.o.**

Ul. Janka Muzykanta 60  
02188 Warszawa - Poland  
sprzedaz@dabpumps.com.pl



**DAB PUMPS B.V.**

Statenlaan, 4  
5223 LA, 's-Hertogenbosch  
Nederland  
info.nl@dabpumps.com  
Tel. +31 416 387280



**DAB PUMPS INC.**

3226 Benchmark Drive  
Ladson, SC 29456 - USA  
info.usa@dwtgroup.com  
Tel. 1- 843-797-5002  
Fax 1-843-797-3366



**DAB PUMPS OCEANIA PTY LTD**

426 South Gippsland Highway,  
Dandenong South VIC 3175 - Australia  
info.oceania@dwtgroup.com  
Tel. +61 1300 378 677



**DAB PUMPS GMBH**

Am Nordpark 3  
D - 41069 Mönchengladbach - Germany  
info.germany@dwtgroup.com  
Tel. +49 2161 47388-0  
Fax +49 2161 47388-36



**DAB PUMPS SOUTH AFRICA (PTY) LTD**

Twenty One industrial Estate,  
16 Purlin Street, Unit B, Warehouse 4  
Olifantsfontein - 1667 - South Africa  
info.sa@dwtgroup.com  
Tel. +27 12 361 3997



**PT DAB PUMPS INDONESIA**

Satrio Tower lantai 26  
unit C-D, Jl. Prof. Dr. Satrio Kav. C4,  
Kel. Kuningan Timur, Kec. Setiabudi, Kota Adm.  
Jakarta Selatan, Prov. DKI Jakarta. - Indonesia  
Tel. +62 2129222850